

Job Report

The Chemical industry places its' trust in ARCTOS

CO₂ / propene cascade refrigeration system for low temperatures

The cascade refrigeration system is widely used where low temperatures are needed. The natural refrigerant CO₂ makes it possible to achieve temperatures as low as -54°C in the low stage. In this case propene is the refrigerant for the upper cascade stage. Using other refrigerants (e.g. ethane), temperatures as low as -85°C can be realized.

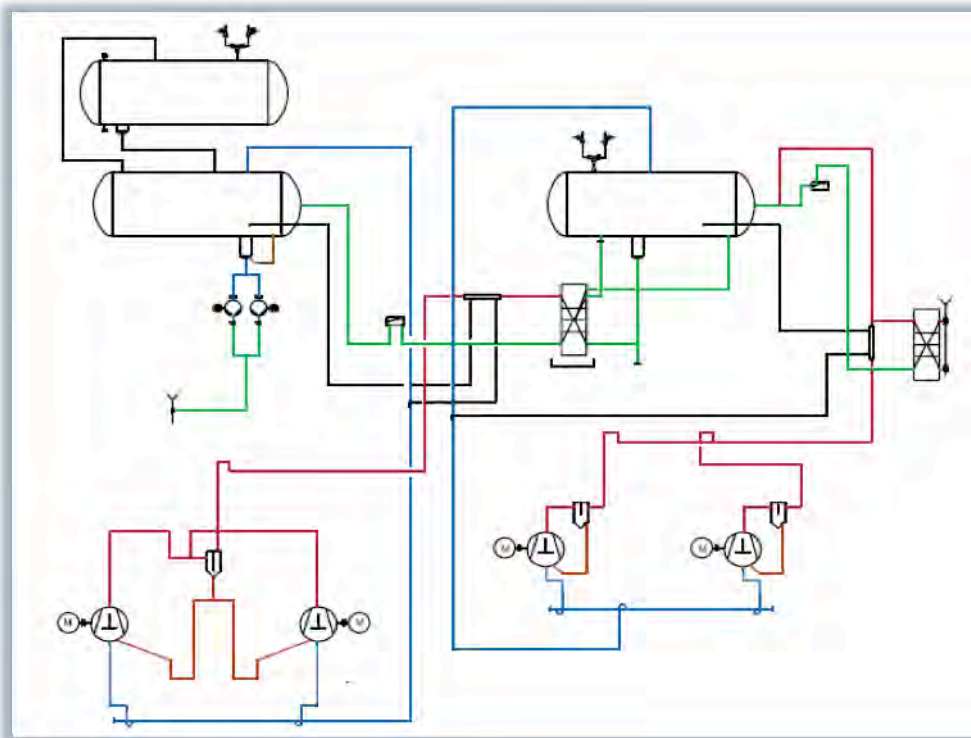

Schematic PI-diagram of the CO₂ / propene-cascade refrigeration system

The most recent cascade project was realized in the chemical industry. In this case a CO₂ / propene cascade refrigeration system cools the continuous synthesis of organic solvents.

At -50°C, the technical components must meet the highest demands. For explosion-proof plants special safety measures must be incorporated.

Only with long-term experience is it possible to design all parts correctly.

Principle:

In the CO₂ / propene cascade refrigeration system built by ARCTOS, two refrigeration units were integrated in each cascade stage. The evaporator (propene) in the high cascade stage is

simultaneously the condenser of the lower cascade stage (CO₂). The liquid CO₂ evaporator cools the chemical process down to -50°C.

The CO₂ high pressure stage is designed for 40 bar pressure.

To avoid excess pressure in the low temperature stage when the unit is stopped, an adequate compensation vessel is provided.

The high cascade stage is condensed by cooling water which is supplied from the customer's network.



Explosion-proof CO₂ / propene cascade refrigeration system in the manufacturer's works, ready for shipment.

Why CO₂?

From the environmental and safety point of view the natural refrigerant CO₂ is an ideal refrigerant which is ideal for attaining low temperatures. It is not toxic, non flammable, causes zero ozone depletion, is chemically inert and inexpensive. Due to its' low volume/capacity flow, CO₂ facilitates compact construction.

Technical data of cascade

Refrigerant	Propene - R1270
Refrigerant charge	240 kg
Max. operating pressure	16 / 25 bar
Propene evaporating temperature	-10°C
Propene condensing temperature	+39°C
Max . total cooling capacity propene	2 x 227 kW (at -10°C)
Compressor manufacturer	GEA Grasso
Compressor model	reciprocating compressors, 2 x Grasso 610
Condenser loading propene	2 x 298 kW cooling water inlet + 31°C cooling water outlet +36°C
Refrigerant	CO₂ - R744
Refrigerant charge	1100 kg
Max. operating pressure	25 / 40 bar
CO ₂ evaporating temperature	-50°C
CO ₂ condensing temperature	-7°C
Max . total cooling capacity CO ₂	2 x 124 kW (at -50°C)
Compressor manufacturer	GEA Grasso
Compressor model	reciprocating compressors, 2 x Grasso 45HP
Condenser loading CO ₂	2 x 164 kW cooling water inlet + 31°C cooling water outlet +36°C